

Power Transmission and Distribution

# 6000 MW UHVDC System and Staged Implementation

High Voltage

SIEMENS



## Main Data of 6000 UHVDC System

		Rectifier	Inverter
DC power	Pdn	6000	
DC current	Idn	3750	
DC voltage	Udn	± 800	± 732
No. of 12p bridges / pole		2	2
Firing angle	alfa	deg	15
Extinction angle	gamma	deg	17
Overlap	u	deg	23.2
Transformer impedance	uk	pu	0.20
Rel. ind. voltage drop	dxn	pu	0.10
Rel. resistive voltage drop	drn	pu	0.004
Total. rel. voltage drop	dxtot	pu	0.104
Transformer sec. voltage	Usecn	KV	172
Transformer rating (1p2w)	S	MVA	304
Converter reactive power	Qdc	MVAr	3362
			3228

SIEMENS



## Staged Development of HVDC Systems

### Reasons for Stage Wise Development of HVDC Systems

- Gradually increase of power demand
- Adding of new power generations in steps
- Optimized time period of investments

### Provisions at Planning Stage

- Reservation of space for expansion in station layout
- Final current ratings for series connected equipment
- Final voltage rating for DC switchyard equipment
- Flexibility of control and protection concept
- Consideration in OHL design

SIEMENS

PTD H176, 17.02.05 3



## Staged Development of HVDC Systems

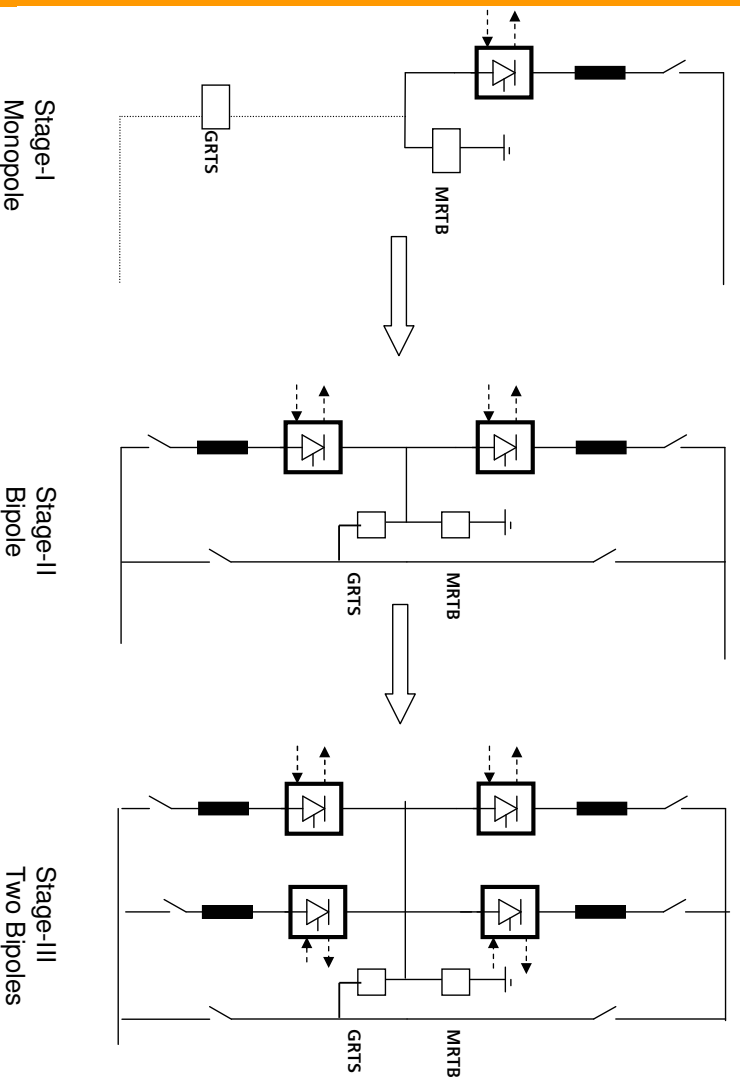

SIEMENS

PTD H176, 17.02.05 4

## Series and Parallel Converter Groups

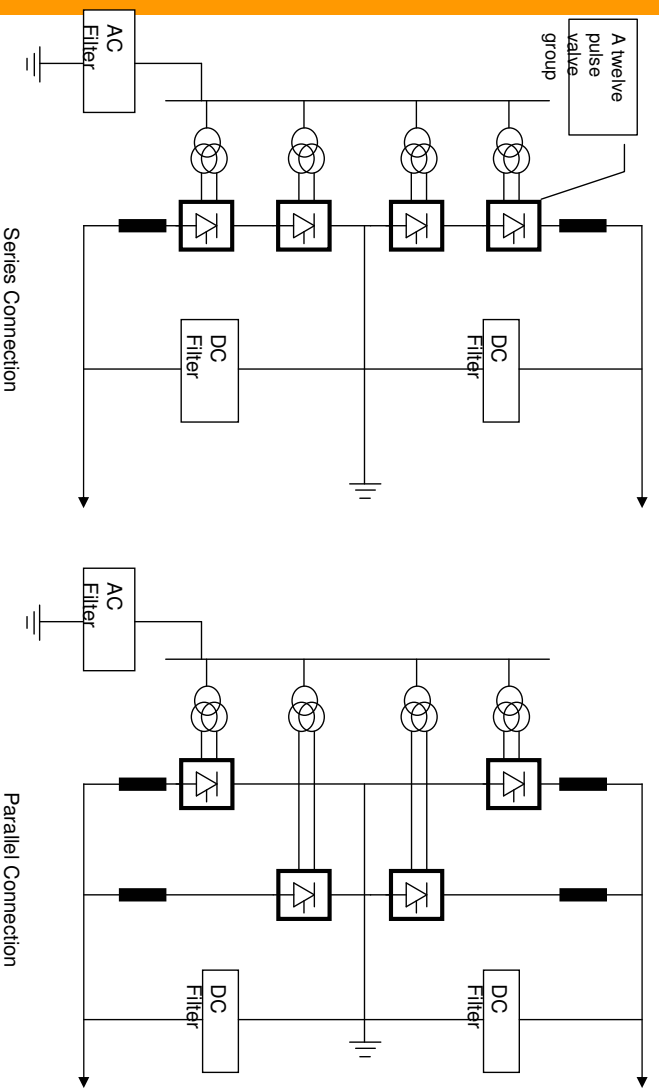

SIEMENS

PTD H176, 17.02.05 5

## Power Evacuation from Hydropower Stations in North East of India

- Target: 6000 MW from North East India to Load Centers
- Alternative 1: 6000 MW with  $\pm 800$  kV with series groups
- Alternative 2: 6000 MW with  $\pm 800$  kV with parallel groups
- Alternative 3: 2 bipoles with 3000 MW each at  $\pm 600$  - 750 kV

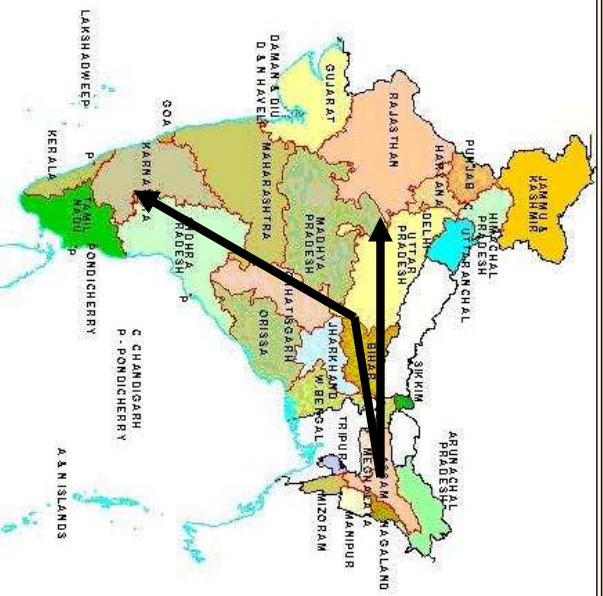

SIEMENS

PTD H176, 17.02.05 6



## Alternative I, Stage I

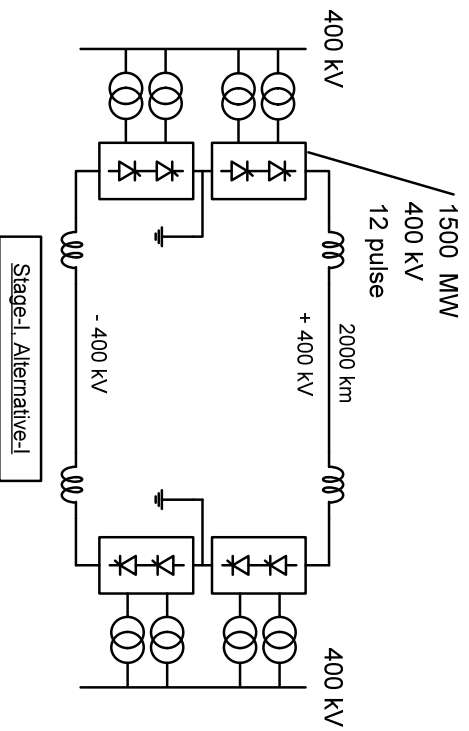

### Highlights

- Build a  $\pm 400$  kV bipole that can deliver 3000 MW continuously
- Highly reliable technology

SIEMENS

PTD H176, 17.02.05 7



## Alternative 2, Stage II

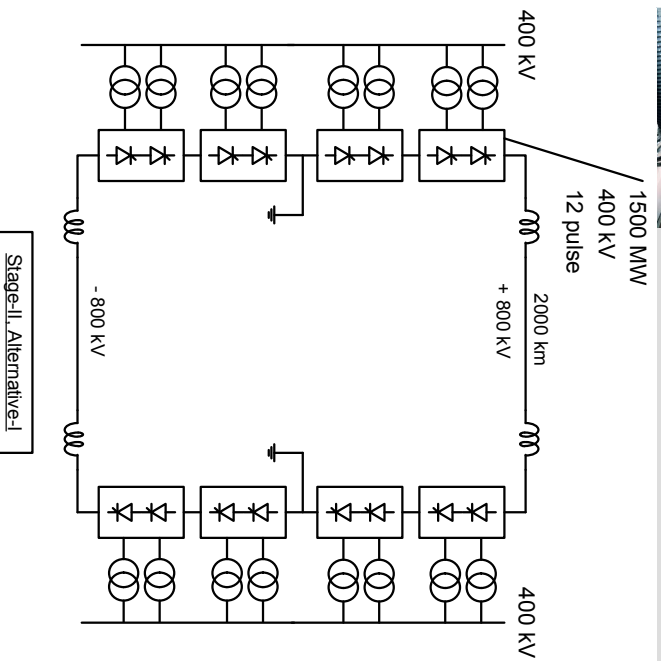

### Highlights

- Add identical series groups and operate both stage-I and stage-II groups at  $\pm 400$  kV to get  $\pm 800$  kV
- On outage of any group, the remaining one in the pole can operate at  $\pm 400$  kV to reduce the impact of outage
- Symmetrical configuration; less complexity e.g. due to uneven sizing of blocks

SIEMENS

PTD H176, 17.02.05 8



## Alternative-II, Stage-I

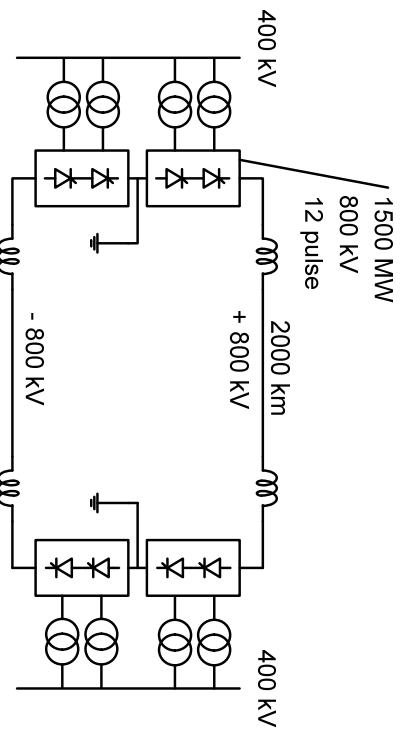

Stage-I, Alternative-II

### Highlights

- Build a 800 kV bipole to deliver 3000 / 4000 MW
- Reduced losses
- Beneficial especially if line is rated for 800 kV in stage-I

SIEMENS

PTD H176, 17.02.05 9



## Alternative-II, Stage-II

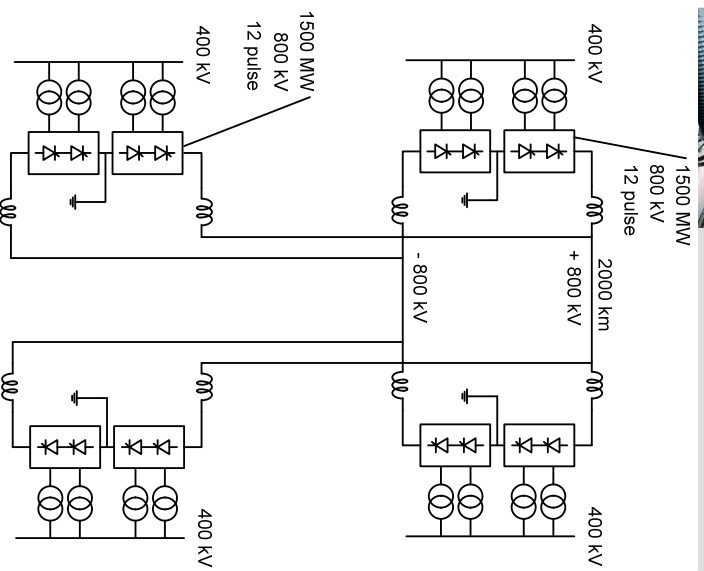

Stage-II, Alternative-II

### Highlights

- Add a second parallel 800 kV block in stage-II
- Avoids multiple series groups
- Parallel groups are generally easier to control
- Possibility for expansion into multi-terminal system with different converter locations

SIEMENS

PTD H176, 17.02.05 10



## Alternative-III, Stage-I

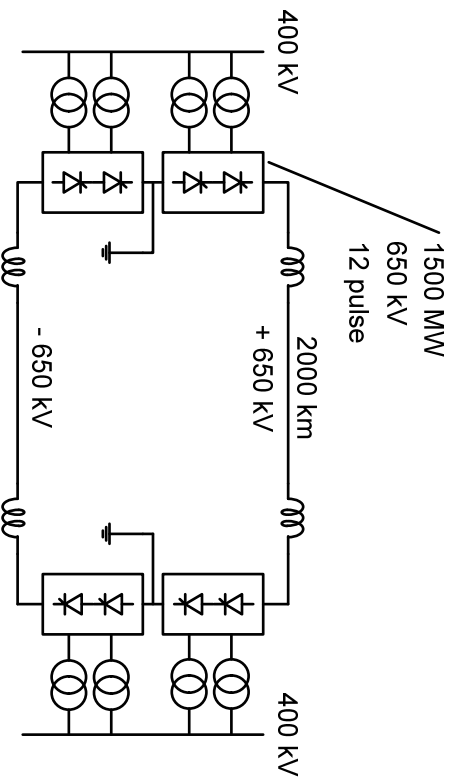

### Highlights

- 600-750 kV to be adapted to length of line
- Greater flexibility in deciding rating of bipole. Up to 4000 MW capacity possible.

SIEMENS

PTD.H176, 17.02.05 11



## Alternative-III, Stage-II

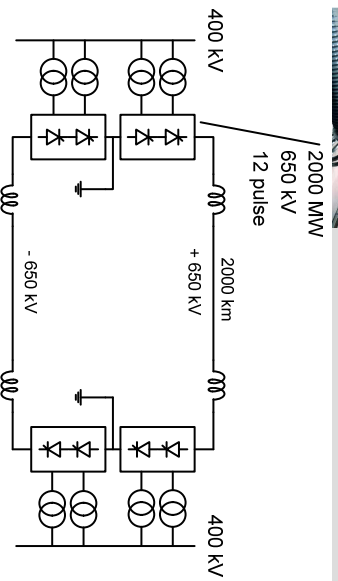

### Highlights

- A separate and possibly identical bipole added
- Ratings of both stage-I and stage-II can be optimized according to ultimate requirements
- No uncertainties on account of lack of experience / R&D of 800 kV DC
- Very high reliability and outage withstand capacity
- Simpler controls, no complicated dc switching arrangement
- Ease of upgradation, greater flexibility

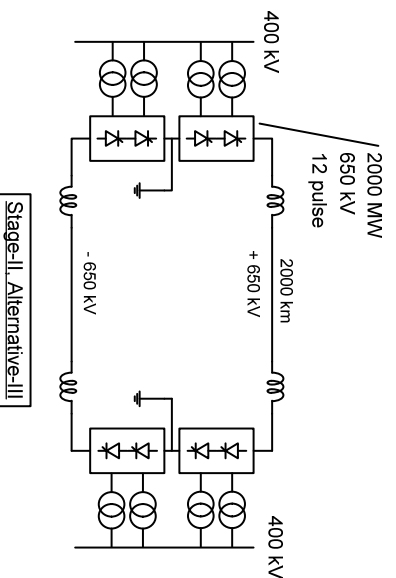

SIEMENS

PTD.H176, 17.02.05 12



## Comparison of Series and Parallel Groups (Stage I)

	Series	Parallel	Series	Parallel	Series	Parallel
Stage 1 [kV]	400 +	800	500 +	800	600 +	800
Stage 2 [kV]	400		300		200	
Power [MW]	3000	3000	3750	3750	4500	4500
Current [A]	3750	1875	3750	2344	3750	2810
Pole Outage [MW]	1500	1500	1875	1875	2250	2250
Bipole Line Losses [MW]	500	125	500	198	500	285
Losses Evaluation [Mio \$]	250	62	250	99	250	142
Station Costs [%]	100	115	125	144	150	173

Loss evaluation: 2 cent / kWh, 5000 hr/a, 5 years for stage I  
 →  $0.02 \times 5000 \times 5 = 500$  US\$ / kW

**Parallel Groups is attractive for staged implementation**

**SIEMENS**

PTD H176, 17.02.05 13



## Two bipole systems vs. single bipole systems

### Advantages:

- supplying more load centers
- Less impact on the AC system in case of bipole load rejection
- better with respect to the reliability and security considerations
- Losing one pole has less impact on ac system due to inherent overload capability in the remaining poles
- transformer rating may allow one 12 pulse converter per pole
- Compacter station layout and dc overhead line construction

### Disadvantages:

- More overhead line corridors needed
- Possibly more investments in converter stations

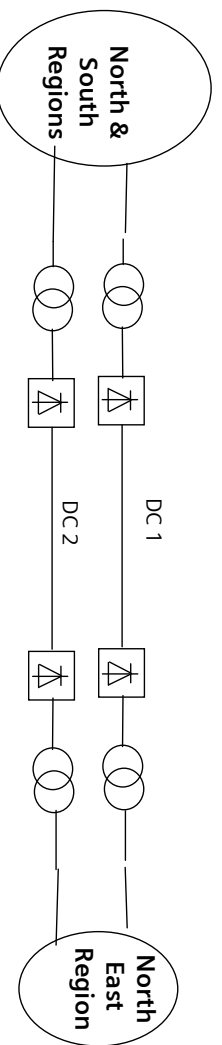

**SIEMENS**

PTD H176, 17.02.05 14



## Conclusion

UHVDC System is ideally suitable for staged implementation. Series converter groups, parallel converter groups and separate bipole schemes are all feasible options for evacuation of large power over long distance.

Final selection shall base on overall evaluation taking line length, power rating and time period between stages into account.

**SIEMENS**